

# ARS 122

## SOIL COMPACTOR BS III

### PROPERLY PRICED AND PRODUCTIVE

The hydrostatic drive of both wheels and the drum ensures traction and travel performance for the Ammann ARS 122 BS III Soil Compactor. The roller is suitable for compaction of a wide range of soil, from silt to crushed stones (gravel). The roller provides an outstanding compaction productivity and efficiency. The machine is equipped with an efficient turbocharged Cummins engine and reliable Rexroth hydraulics.

### TRACTION AND MANOEUVRABILITY

- Hydraulic propulsion of wheels with independent hydromotors – no axles
- Low centre of gravity for stability and manoeuvrability

### OPERATOR FRIENDLY

- Clear dashboard layout enables easy and safe operation.
- Fully insulated operator platform for maximum operator comfort

### INDUSTRY-LEADING COMPACTION

- High-performing Ammann vibratory system
- Two-stage vibratory system
- Maximum compaction forces transferred to material
- PD shells option available

### TIME AND COST SAVER

- Easily accessible maintenance points
- Superior fuel efficiency

### APPLICATIONS

- Medium and large jobsites
- Transport construction (motorways, railways, airfields)
- Construction (industrial zones, harbours)
- Compaction of all kinds of soils and wet paves

#### MAXIMUM COMPACTED LIFT THICKNESS AT OPTIMAL WORKING CONDITIONS

	Rockfill	Sand / gravel	Mixed soils	Silt	Clay
ARS 122	0,8 m (in)	0,6 m (in)	0,5 m (in)	*0,4 m (16 in)	*0,3 m (12 in)

\*With PD shells

# AMMANN

TECHNICAL SPECIFICATIONS  
ARS 122 SOIL COMPACTOR

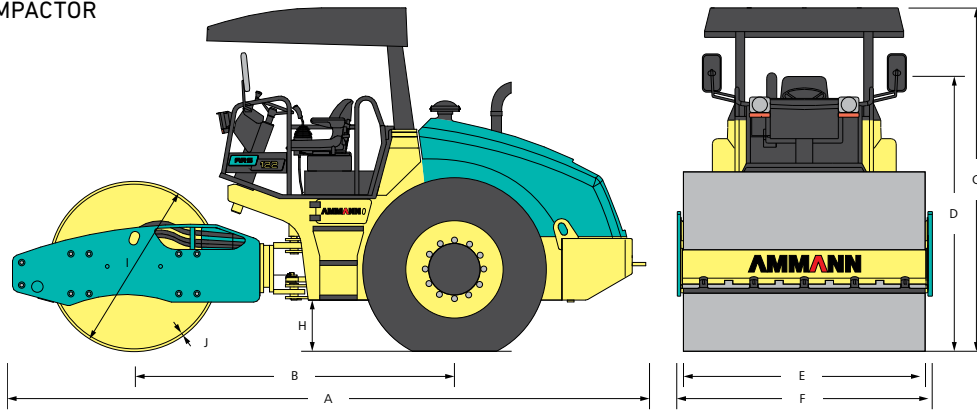

**DIMENSIONS**

A	MACHINE LENGTH	5460 mm
B	WHEELBASE	2820 mm
C	MACHINE HEIGHT	3030 mm
D	MACHINE HEIGHT (REMOVED ROPS)	2375 mm
E	DRUM WIDTH	2130 mm
F	MACHINE WIDTH	2260 mm
G	MACHINE LENGTH (BLADE)	-
H	GROUND CLEARANCE	450 mm
I	DRUM DIAMETER	1500 mm
J	DRUM SHELL THICKNESS	25 mm
K	MACHINE WIDTH (BLADE)	-

**MISCELLANEOUS**

BRAKES OPERATING	Hydrostatic
BRAKES PARKING	SAHR
BRAKES EMERGENCY	SAHR
FUEL TANK CAPACITY	410 l
VOLTAGE	12 V

**WEIGHT & DRIVING CHARACTERISTIC**

OPERATING WEIGHT	11 200 kg
MAXIMUM WEIGHT	13 180 kg
STATIC LINEAR LOAD	29.6 kg/cm
MAX. TRANSPORT SPEED	10.3 km/h
MAX. WORKING SPEED	5 km/h
CLIMBING ABILITY	40 %
TURNING RADIUS INNER (EDGE)	3210 mm

**STANDARD VERSION**

- Operator platform with rails
- Sun canopy
- Back-up alarm
- Toolbox
- Lockable vandal guard
- Engine pre-cleaner

**COMPACTION FORCES**

FREQUENCY I	32 Hz
FREQUENCY II	35 Hz
FREQUENCY ACE MIN./MAX.	-
AMPLITUDE I	1.85 mm
AMPLITUDE II	1.15 mm
AMPLITUDE ACE MIN./MAX.	-
CENTRIFUGAL FORCE I	277 kN
CENTRIFUGAL FORCE II	206 kN
CENTRIF. FORCE ACE MIN./MAX.	-

**ENGINE**

MANUFACTURER	Cummins 4BTAA 3.9-C99 / or Equivalent
POWER ACCORDING TO ISO 3046-1	74 kW/2200 rpm (99 HP/2200 rpm)
MAXIMUM TORQUE	391/1300 Nm/rpm
ENGINE COMPLIES WITH EMISSION REGULATIONS	Bharat Stage III (BS III)



**OPTIONAL ITEMS**

- Set of tools
- PD shell kit
- Compaction meter
- Tractor tyres
- Warning beacon
- Engine cold start kit
- Fire extinguisher