

APF 12/40

FORWARD MOVING VIBRATORY PLATE



A STRONG ALL-AROUND PERFORMER

A powerful, efficient petrol engine brings optimal machine performance to this plate compactor. The engine is also environmentally friendly, thanks to exceptional fuel consumption, minimal maintenance needs and low sound levels. The machine works well in many applications and is commonly utilised on small soil and asphalt jobsites. A 10-litre water tank, large for this particular machine class, is an option appreciated by many contractors

EFFECTIVE COMPACTION TOOL

- A powerful petrol engine is the force behind the exciter unit and the foundation for the plate's exceptional compaction performance.
- A centrifugal clutch and V belt effectively transfer power to the exciter system that delivers the powerful forward movement.
- An optional water sprinkling system enables work on bituminous surfaces and greatly enhances the compactor's versatility.
- An extended-life exciter unit stretches service intervals and reduces maintenance costs.
- The base plate utilises wear-resistant materials and a self-cleaning design to lengthen the unit's life.

IMPROVED GUIDE HANDLE

- The vibration-isolated guide handle reduces operator stress, permitting longer working shifts while minimising the risk of injury.
- The handle can be folded flush with the machine or even removed, enhancing manoeuvrability in tight spaces and making transport easy.

APPLICATIONS

- Compaction in confined areas
- Earthwork
- Asphalt and paving applications
- Light to medium patchwork
- Pipeline and trench construction
- Landscaping and gardening

AMMANN

TECHNICAL SPECIFICATIONS
APF 12/40 FORWARD MOVING VIBRATORY PLATE

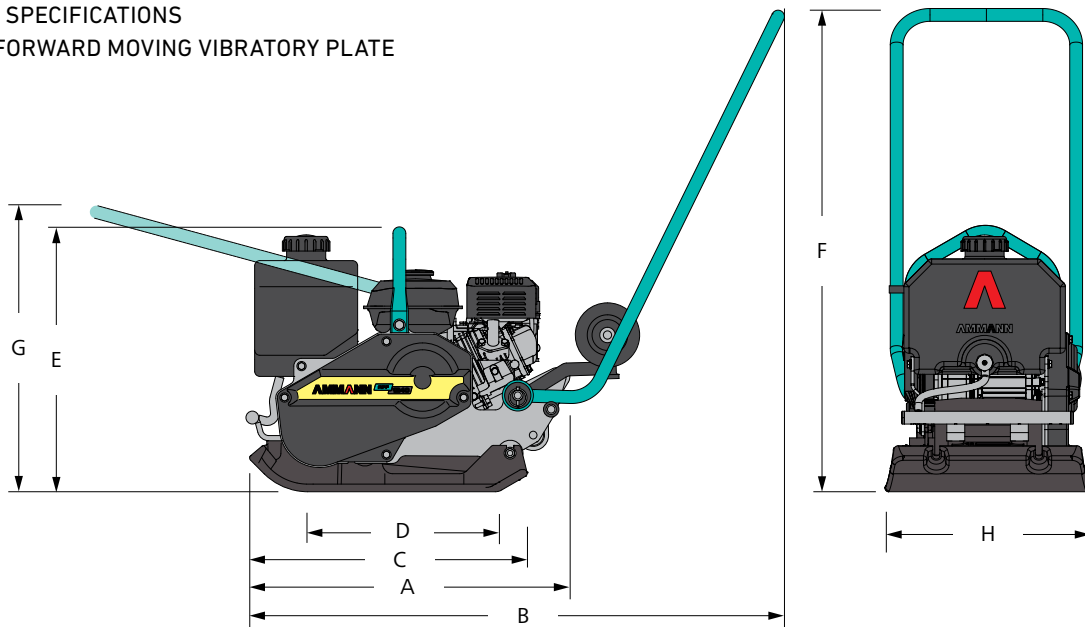

DIMENSIONS & WEIGHTS

| | |
|--|---|
| MACHINE WEIGHT | 69 ⁽¹⁾ /70 kg (152 ⁽¹⁾ /154 lb) |
| MACHINE WEIGHT (INCL. OPTIONAL SPRINKLER & WHEELS) | 76 ⁽¹⁾ /77 kg (168 ⁽¹⁾ /170 lb) |
| A MACHINE LENGTH | 621 mm (24.4 in) |
| B MACHINE LENGTH WITH HANDLE | 1040 mm (40.9 in) |
| C BASE PLATE LENGTH | 540 mm (21.3 in) |
| D GROUND CONTACT LENGTH | 371 mm (14.6 in) |
| E MACHINE HEIGHT | 514 mm (20.2 in) |
| F WITH HANDLE (WORK) | 1000 mm (39.4 in) |
| G WITH HANDLE (TRANSPORT) | 1100 mm (43.3 in) |
| H MACHINE WIDTH | 400 mm (15.7 in) |

COMPACTION FORCES

| | |
|--------------------------|---|
| MAX. VIBRATION FREQUENCY | 98 Hz (5880 vpm) |
| MAX. CENTRIFUGAL FORCE | 12 kN (2698 lbf) |
| WORKING SURFACE | 480 m ² /h (5167 ft ² /h) |
| SPEC. SURFACE PRESSURE | 8.1 N/cm ² (11.7 psi) |

⁽¹⁾B&S XR 550

STANDARD EQUIPMENT

- Standard vibration isolated guide handle
- Central lifting point
- Powerful and reliable petrol engine
- Service friendly exciter unit with expanded life expectancy
- Well protected, sturdy centrifugal clutch and V-Belt

ENGINE

| | | |
|----------------------|-------------------------|-------------------------|
| ENGINE | B&S XR 550 | Honda GX 120 |
| FUEL | Petrol | Petrol |
| ENGINE OUTPUT AT RPM | 2.6 kW (3.5 HP) 3600 | 2.6 kW (3.5 HP) 3600 |

MISCELLANEOUS

| | |
|------------------------------|--------------------------|
| HAND-ARM VIBRATION ON HANDLE | 3.0 m/s ² |
| SPEED | 0–20 m/min (65.6 ft/min) |
| GRADEABILITY | 30% |
| MAX. INCLINE TO ALL SIDES | 20° |

OPTIONS

| | |
|------------------------|-----------------------|
| RUBBER MAT | x |
| TRANSPORT WHEELS | x |
| WATER SPRINKLER SYSTEM | 10 l (2.641 U.S. gal) |

OPTIONAL EQUIPMENT

- Permanently installed transport wheels
- Vulcolan mat for application on paving stones
- Corrosion free water tank and sprinkling system for application on bituminous surfaces
- 3 year extended Warranty Program